

# IcedID Botnet Distributors Abuse Google PPC to Distribute Malware

By: Ian Kenefick Dec 23, 2022 Read time: 4 min (1167 words)

Published: 2022-12-23 · Archived: 2026-04-05 14:29:41 UTC

## Malware

We analyze the latest changes in IcedID botnet from a campaign that abuses Google pay per click (PPC) ads to distribute IcedID via malvertising attacks.

---

After closely tracking the activities of the [IcedID botnetnews- cybercrime-and-digital-threats](#), we have discovered some significant changes in its distribution methods. Since December 2022, we observed the abuse of Google pay per click (PPC) ads to distribute IcedID via [malvertisingnews- cybercrime-and-digital-threats](#) attacks. This IcedID variant is detected by Trend Micro as TrojanSpy.Win64.ICEDID.SMYXCLGZ.

Advertising platforms like [Google Ads](#) enable businesses to display advertisements to target audiences for the purpose of boosting traffic and increasing sales. Malware distributors abuse the same functionality in a technique known as malvertising, wherein chosen keywords are hijacked to display malicious ads that lure unsuspecting search engine users to downloading malware.

In our investigation, malicious actors used malvertising to distribute the IcedID malware via cloned webpages of legitimate organizations and well-known applications. Recently, the Federal Bureau of Investigation (FBI) [published a warning](#) pertaining to how cybercriminals abuse search engine advertisement services to imitate legitimate brands and direct users to malicious sites for financial gain.

Our blog entry provides the technical details of IcedID botnet's new distribution method and the new loader it uses.

## Technical analysis

Organic search results are those generated by the [Google PageRank algorithm](#), whereas [Google Ads appear](#) in more prominent locations above, beside, below, or with the organic search results. When these ads are hijacked by malicious actors via malvertising, they can lead users to malicious websites.

## Targeted brands and applications

In our investigation, we discovered that IcedID distributors hijacked the keywords used by these brands and applications to display malicious ads:

1. Adobe – A computer software company
2. AnyDesk - A remote control application
3. Brave Browser - A web browser

4. Chase Bank - A banking application
5. Discord - An instant messenger service
6. Fortinet - A security company
7. GoTo - A remote control application
8. Libre Office - An open-source alternative to Microsoft Office
9. OBS Project - A streaming application
10. Ring - A home CCTV (closed-circuit) manufacturer
11. Sandboxie - A virtualization/sandbox application
12. Slack - An instant messaging application
13. Teamviewer - A remote control application
14. Thunderbird - An email client
15. US Internal Revenue Service (IRS) – A US federal government body

The malicious websites where victims are directed are made to look like their legitimate counterparts. Figure 1 shows a legitimate-looking malicious Slack webpage used by IcedID distributors to lure victims into downloading malware.

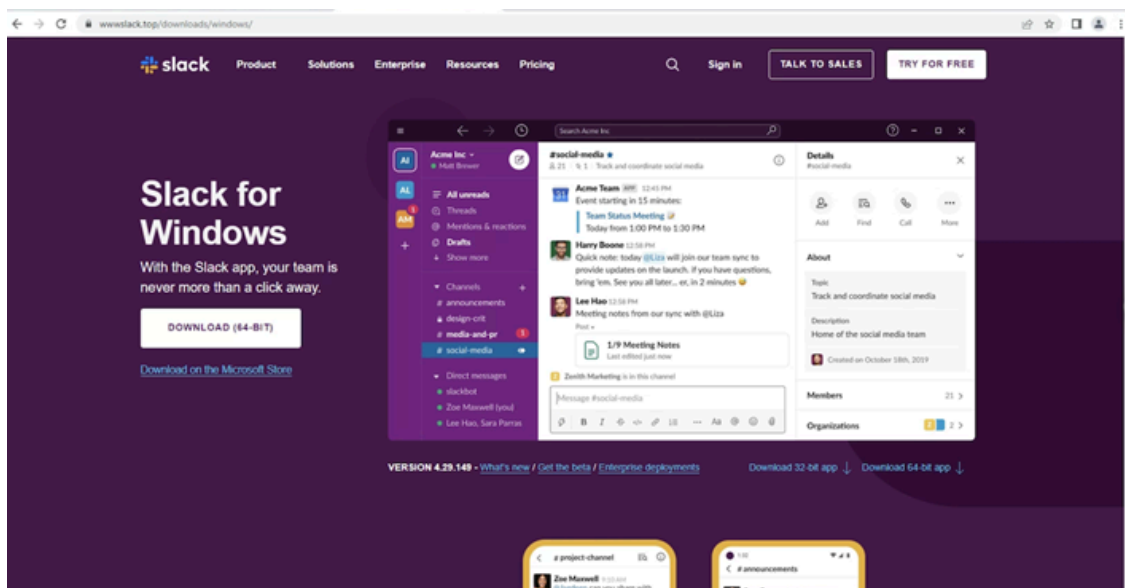

Figure 1. A legitimate-looking malicious Slack webpage used by IcedID distributors

#### Infection chain

The overall infection flow involves delivering the initial loader, fetching the bot core, and ultimately, dropping the payload. The payload is typically a backdoor.

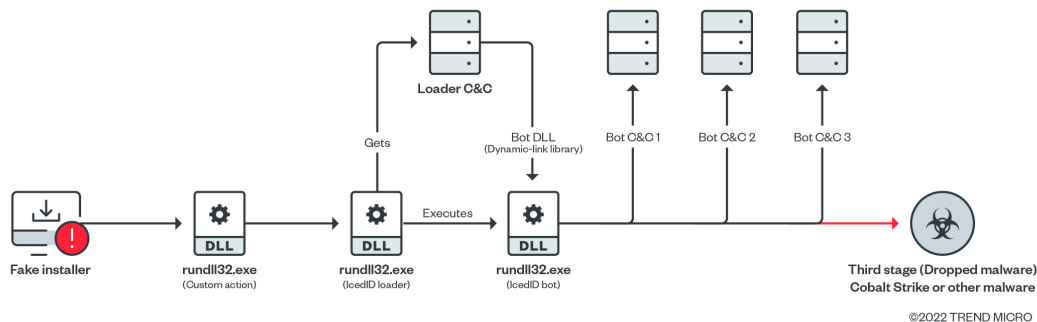

Figure 2. IcedID botnet malware infection chain

### Infection via malvertising

1. A user searches for an application by entering a search term on Google. In this particular example, the user wants to download the AnyDesk application and enters the search term “AnyDesk” on the Google search bar.
2. A malicious ad for the AnyDesk application that leads to a malicious website is displayed above the organic search results.
3. IcedID actors abuse the legitimate Keitaro Traffic Direction System (TDS), to filter researcher and sandbox traffic. The victim is then redirected to a malicious website.
4. Once the user selects the “Download” button, it downloads a malicious Microsoft Software Installer (MSI) or Windows Installer file inside a ZIP file in the user’s system.

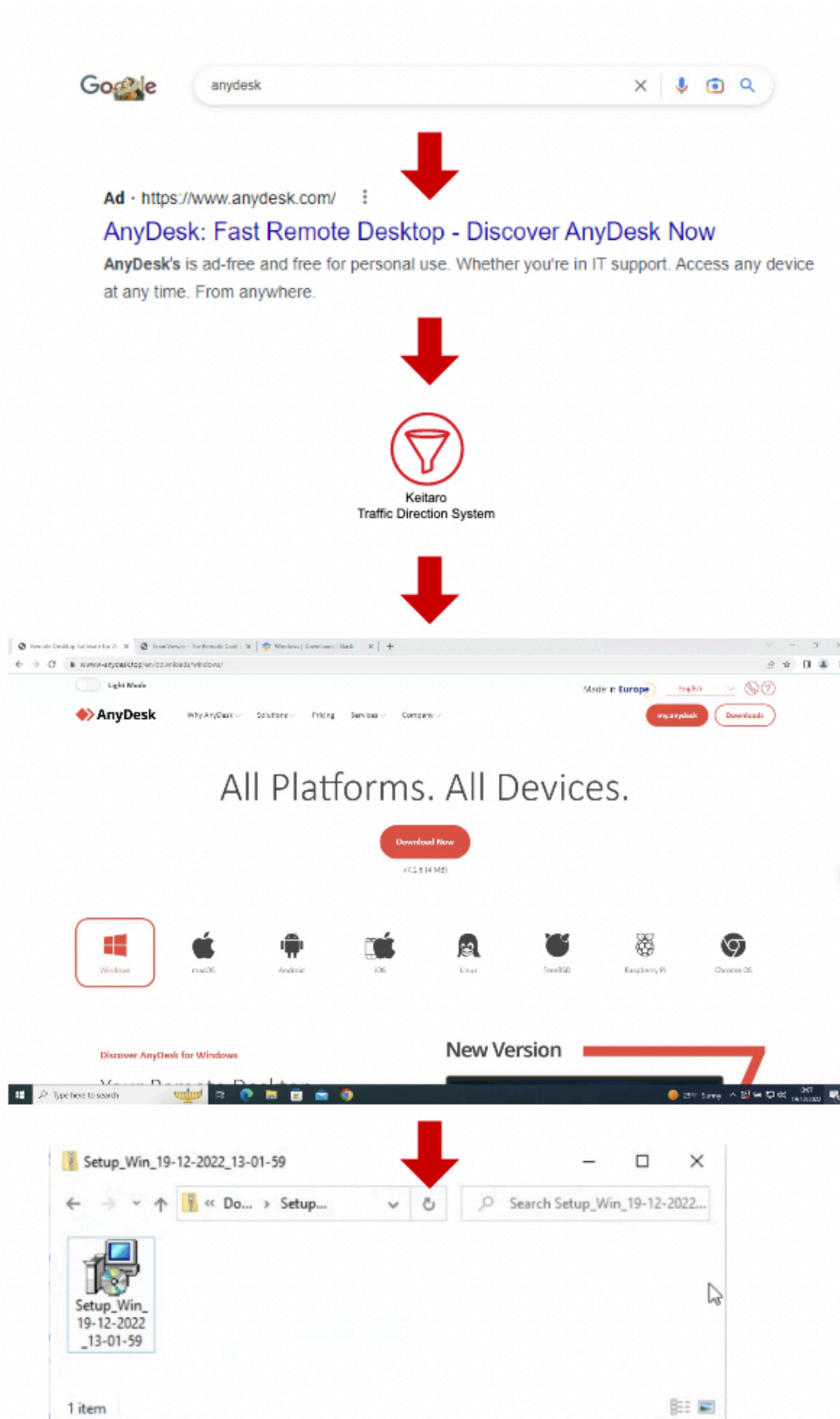

Figure 3. IcedID botnet malvertising infection chain

## The new IcedID botnet loader

In this campaign, the loader is dropped via an MSI file, which is atypical for IcedID.

The installer drops several files and invokes the “init” export function via rundll32.exe, which then executes the malicious loader routine.

This “loader” DLL has the following characteristics:

- The authors have taken a legitimate DLL and replaced a single legitimate function with the malicious loader function using the “init” export function name at the last ordinal.
- The first character of each legitimate export function in the IcedID loader is replaced with the letter “h.”
- The reference to the malicious function is a patched legitimate function.

The resulting malicious file is almost identical to the legitimate version. This can prove to be challenging for [machine learning \(ML\)](#) detection solutions.

On the surface, the malicious IcedID and legitimate sqlite3.dll files look almost identical. Figure 4 shows a side-by-side comparison of these files using the [PortEx Analyzer tool](#), which was developed by security researcher Karsten Hahn. The tool allows us to quickly visualize the structure of the portable executable (PE) files, and, in this case, assess the similarity of files.

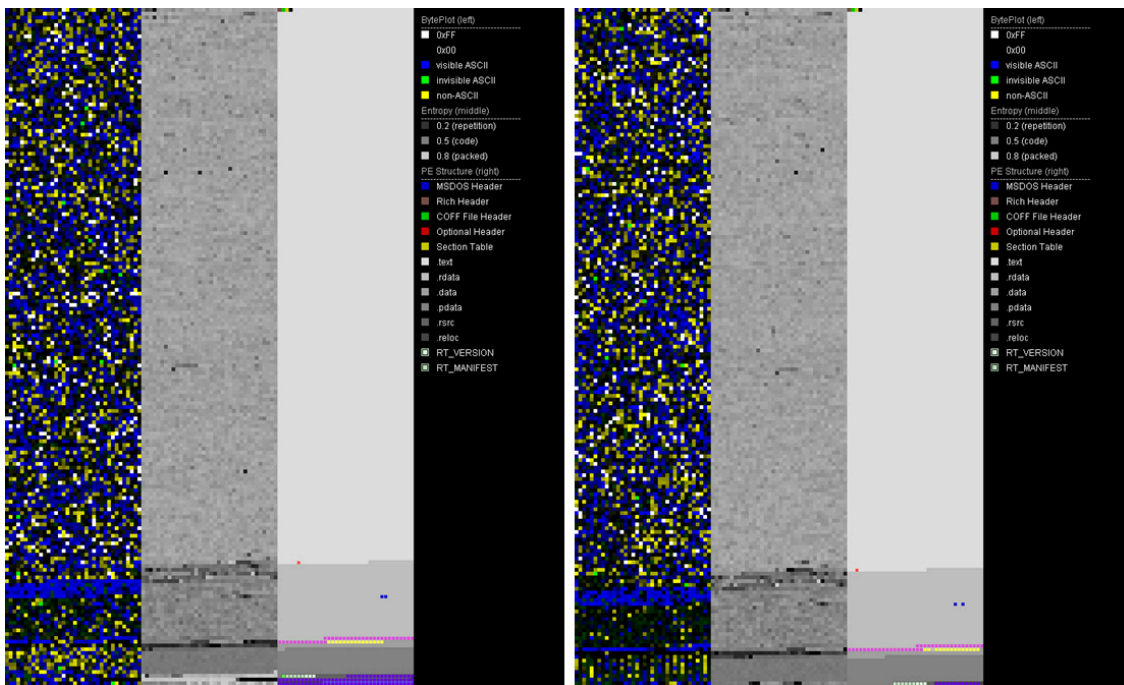

Figure 4. A visual representation of the malicious IcedID (left) and legitimate PE (right) files (using Karsten Hahn’s PortEx Analyzer tool)

For this reason, we hypothesize that this is an attack on two types of malware detection technologies:

- Machine learning detection engines
- Whitelisting systems

## Tampered DLL files functioning as IcedID loaders

We have observed that some of the files that have been modified to act as IcedID loaders are well-known and widely used libraries.

Table 1. Files that have been modified to act as IcedID loaders

DLL name	Description
tcl86.dll	A library component of ActiveState’s TCL (Tool Command Language) Programming Language Interpreter
sqlite3.dll	A library component of SQLite database
ConEmuTh.x64.dll	A plugin for Far Manager
libcurl.dll	A CURL library

In sqlite3.dll, we observed that the function at ordinal 270 “sqlite3\_win32\_write\_debug” has been replaced with the malicious “init” function in the IcedID loader.

This is the case across the modified DLL files listed above: The export function at the last ordinal is replaced with the malicious “init” function.

Name	Address	Ordinal	Name	Address	Ordinal
sqlite3_value_numeric_type	000000018003A540	237	sqlite3_value_numeric_type	000000018003A540	237
sqlite3_value_pointer	000000018003A560	238	sqlite3_value_pointer	000000018003A560	238
sqlite3_value_subtype	000000018003A550	239	sqlite3_value_subtype	000000018003A550	239
sqlite3_value_text	000000018003A580	240	sqlite3_value_text	000000018003A580	240
sqlite3_value_text16	000000018003A5F0	241	sqlite3_value_text16	000000018003A5F0	241
sqlite3_value_text16be	000000018003A630	242	sqlite3_value_text16be	000000018003A630	242
sqlite3_value_text16le	000000018003A670	243	sqlite3_value_text16le	000000018003A670	243
sqlite3_value_type	000000018003A680	244	sqlite3_value_type	000000018003A680	244
sqlite3_version	0000000180134788	245	sqlite3_version	0000000180134788	245
sqlite3_vfs_find	0000000180004880	246	sqlite3_vfs_find	0000000180004880	246
sqlite3_vfs_register	0000000180004C90	247	sqlite3_vfs_register	0000000180004C90	247
sqlite3_vfs_unregister	0000000180004D70	248	sqlite3_vfs_unregister	0000000180004D70	248
sqlite3_vmprintf	0000000180008D00	249	sqlite3_vmprintf	0000000180008D00	249
sqlite3_vsnprintf	0000000180008EE0	250	sqlite3_vsnprintf	0000000180008EE0	250
sqlite3_vtab_collation	00000001800B2370	251	sqlite3_vtab_collation	00000001800B2370	251
sqlite3_vtab_config	00000001800A4D30	252	sqlite3_vtab_config	00000001800A4D30	252
sqlite3_vtab_nochange	000000018003C0D0	253	sqlite3_vtab_nochange	000000018003C0D0	253
sqlite3_vtab_on_conflict	00000001800A4D10	254	sqlite3_vtab_on_conflict	00000001800A4D10	254
sqlite3_wal_autocheckpoint	00000001800C6E70	255	sqlite3_wal_autocheckpoint	00000001800C6E70	255
sqlite3_wal_checkpoint	00000001800C70A0	256	sqlite3_wal_checkpoint	00000001800C70A0	256
sqlite3_wal_checkpoint_v2	00000001800C6F70	257	sqlite3_wal_checkpoint_v2	00000001800C6F70	257
sqlite3_wal_hook	00000001800C6F00	258	sqlite3_wal_hook	00000001800C6F00	258
sqlite3_win32_is_nt	000000018000C720	259	sqlite3_win32_is_nt	000000018000C720	259
sqlite3_win32_mbcst_to_utf8	000000018000CD00	260	sqlite3_win32_mbcst_to_utf8	000000018000CD00	260
sqlite3_win32_mbcst_to_utf8_v2	000000018000CD30	261	sqlite3_win32_mbcst_to_utf8_v2	000000018000CD30	261
sqlite3_win32_set_directory	000000018000CFD0	262	sqlite3_win32_set_directory	000000018000CFD0	262
sqlite3_win32_set_directory16	000000018000CEF0	263	sqlite3_win32_set_directory16	000000018000CEF0	263
sqlite3_win32_set_directory8	000000018000CDE0	264	sqlite3_win32_set_directory8	000000018000CDE0	264
<b>sqlite3_win32_sleep</b>	<b>000000018000C6D0</b>	<b>265</b>	<b>sqlite3_win32_sleep</b>	<b>000000018000C6D0</b>	<b>265</b>
sqlite3_win32_unicode_to_utf8	000000018000CCD0	266	sqlite3_win32_unicode_to_utf8	000000018000CCD0	266
sqlite3_win32_utf8_to_mbcst	000000018000CD70	267	sqlite3_win32_utf8_to_mbcst	000000018000CD70	267
sqlite3_win32_utf8_to_mbcst_v2	000000018000CDA0	268	sqlite3_win32_utf8_to_mbcst_v2	000000018000CDA0	268
sqlite3_win32_utf8_to_unicode	000000018000CCA0	269	sqlite3_win32_utf8_to_unicode	000000018000CCA0	269
init	000000018012AB40	270	sqlite3_win32_write_debug	000000018000C640	270
<b>DllEntryPoint</b>	<b>000000018012C134</b>	<b>[main entry]</b>	<b>DllEntryPoint</b>	<b>000000018012C134</b>	<b>[main entry]</b>

Figure 5. A comparison of IcedID-modified (left) and normal (right) files, wherein the former’s export function at the last ordinal is replaced with the malicious “init” function

Further investigation shows that the structure of the file is identical.

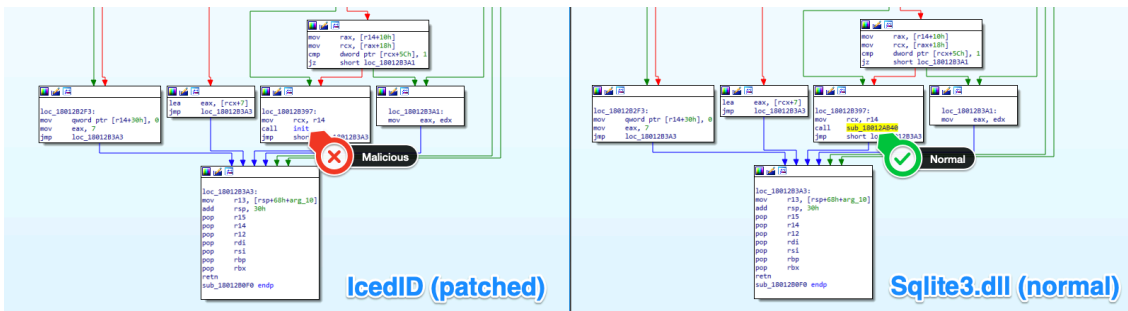

Figure 6. A comparison of IcedID-modified and normal files wherein both files show an identical structure

**Execution**

1. “MsiExec.exe” executes (parent process) (MITRE ID T1218.007 - System Binary Proxy Execution: msiexec)
2. “rundll32.exe” is spawned (MITRE ID T1218.011 - System Binary Proxy Execution: rundll32.exe)
3. “rundll32.exe” runs the custom action “Z3z1Z” via “zzzzInvokeManagedCustomActionOutOfProc” (MITRE ID T1218.011 - System Binary Proxy Execution: rundll32.exe)
4. The custom action spawns a second “rundll32.exe” to run the IcedID loader “MSI3480c3c1.msi” with the “init” export function (MITRE IDs T1027.009 - Embedded Payloads and T1218.011 - System Binary Proxy Execution: rundll32.exe)

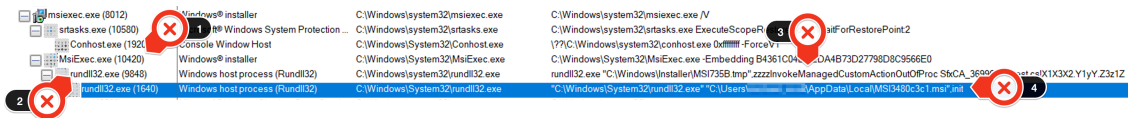

Figure 7. IcedID loader execution chain

Tables	Action	Type	Source	Target
AdminExecuteSequence	Z3z1Z	65	Z3z1Z_File	Z3z1Z
AdminUISequence				
AdvtExecuteSequence				
Binary				
Component				
CreateFolder				
CustomAction				

Figure 8. MSI custom action

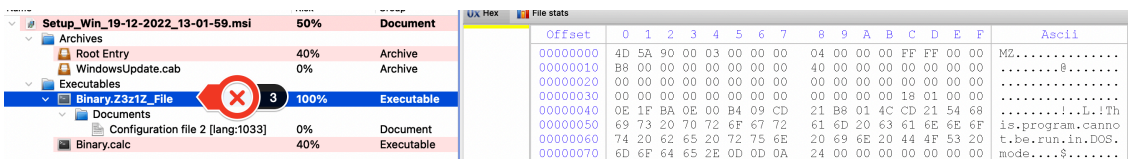

Figure 9. MSI structure that contains the custom action

### Conclusion

IcedID is a noteworthy malware family that is capable of delivering other payloads, including Cobalt Strike and other malware. IcedID enables attackers to perform highly impactful follow through attacks that lead to total system compromise, such as data theft and crippling ransomware. The use of malvertising and an evasive loader is a reminder of why it's important for businesses to deploy layered security solutions that include custom sandboxing, predictive machine learning, behavior monitoring and file and web reputation detection capabilities. Users can also consider the use of ad blockers to help thwart malvertising attacks.

### Indicators Of Compromise (IOCs)

The indicators of compromise can be accessed via this [text fileopen on a new tab](#).

### Mitre ATT&CK

ID	Name	Description
<b>T1218.007</b>	System Binary Proxy Execution msiexec	IcedID is delivered via an MSIEXEC package which execute a malicious custom action to deploy the IcelD Loader
<b>T1218.011</b>	System Binary Proxy Execution rundll32.exe	The malicious custom action invokes rundll32.exe to execute the IcelD Loader
<b>T1027.009</b>	Embedded Payloads	Attackers embed a malicious function in an otherwise benign DLL in order to thwart detection technologies

©2022 TREND MICRO

### Tags

---

Source: [https://www.trendmicro.com/en\\_us/research/22/1/icedid-botnet-distributors-abuse-google-ppc-to-distribute-malware.html](https://www.trendmicro.com/en_us/research/22/1/icedid-botnet-distributors-abuse-google-ppc-to-distribute-malware.html)