

Virus Bulletin :: VB2017 paper: Nine circles of Cerber

Archived: 2026-04-05 17:36:03 UTC

Stanislav Skuratovich & Neomi Rona

Check Point Software Technologies, Belarus & Israel

Copyright © 2017 Virus Bulletin

Abstract

Without any doubt, 2016 was the year of ransomware. What makes ransomware so attractive to attackers is that it offers the possibility of large profits while not requiring too much effort. With the availability of ransomware-as-a-service, someone with very little actual knowledge of computers can easily manage a highly profitable campaign.

A wide variety of different ransomware families appeared over the course of the last year, including Locky, CryptoWall and CryptXXX, to name just a few. Let's talk about the very profitable Cerber.

The Cerber ransomware was mentioned for the first time in March 2016 on some Russian underground forums, on which it was offered for rent in an affiliate program. Since then, it has been spread massively via exploit kits, infecting more and more users worldwide, mostly in the APAC (Asia-Pacific) region. At the time of writing this paper, there are six major versions.

There have been multiple successful attempts to decrypt users' files without paying a ransom. At the end of July 2016, *Trend Micro* released a partially working decryptor for the first version of Cerber [1]. In early August, we had a chance to take a look at the original Cerber decryptor code that was available for download upon payment of the ransom. Our main goal was to discover a flaw, based on the standard approaches we use against ransomware.

From our perspective, it wouldn't be as much fun if this was one of the expected bugs – and fortunately, the one we discovered wasn't. However, as with any flaw, you need to hide the solution from the criminals. In an ironic twist, the ransomware authors released a new Cerber 2 version the day before we were due to release the decryptor.

In order to be able to provide our decryption tool to as many victims as possible, we gathered forces and adapted it to the new version on the same day, thus managing to release it on time. The tool was used by many victims worldwide.

This paper details the story of the ransomware's fatal flaw and our free decryption service [2, 3]. We will dive deep into the background of Cerber as a service, the business operations, the money flow between the attacker and the affiliate, full global infection statistics and the estimated overall profit of the criminals [4].

1. Introduction

In this paper we discuss one of the largest recent ransomware campaigns, known as Cerber. We describe the ransomware's encryption routine and reveal technical details of the server-side vulnerability that was used for the successful decryption of thousands of infected machines. We also share information on the money flow and estimated overall profit of the criminals, together with the tools used to collect that information. The decryption software will be available as open source on our *GitHub* repository [5].

2. Encryption scheme

Let's describe the encryption scheme used by the Cerber ransomware. It uses mix of symmetric and asymmetric encryption algorithms, such as RC4 and RSA. Almost all the encryption keys are generated randomly on the victim's machine.

First, let's take a look at the keys that are used by Cerber during the encryption process:

Key	Appearance/description	Scope
RSA_M_PUB (2048 bits)	Configuration This is a master public key	Global
RSA_X_PUB/PRI (X bits)	Random This is a local key pair	Global
RC4_KEY (128 bytes)	Random	Per file

The structure of the encrypted file is presented in [Figure 1](#).

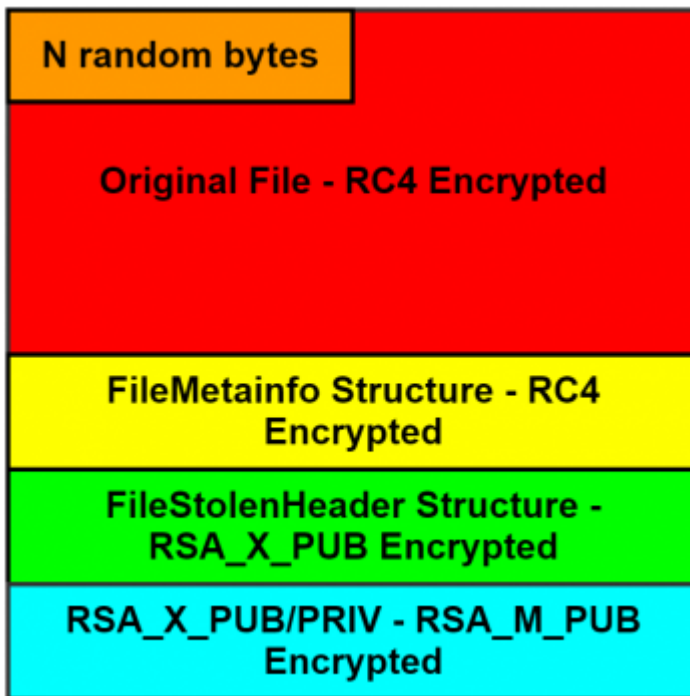

Figure 1: Structure of encrypted file.

The goal of the encryption routine is to encrypt a single file from the file system. The number of bytes that are stolen from the beginning of each encrypted file (hereafter called *N*) is calculated once and depends on the local RSA key size. The steps performed by Cerber to encrypt a single file are as follows:

1. Calculate the number of blocks that will be encrypted (up to the maximum number of blocks specified in the configuration).
2. Steal *N* bytes from the beginning of the file by replacing them with random bytes.
3. Encrypt each block with the RC4 algorithm using RC4_KEY as a key.
4. The following meta information is encrypted and appended to the end of the processed file:

Information	Algorithm	Key
FileMetainfo	RC4	RC4_KEY
FileStolenHeader	RSA	RSA_X_PUB
RSA_X_PUB/PRI	RSA	RSA_M_PUB

The FileStolenHeader contains RC4_KEY, which can be used to restore the encrypted blocks, thus it is encrypted using RSA_X_PUB. RSA_X_PRI is encrypted by the master RSA_M_PUB key, because it can be used for the FileStolenHeader decryption.

Two main data structures that represent the encrypted file are presented below:

```
struct FileStolenHeader {
    char ver_magic[4]; // magic header (version)
    uint32_t rand_bytes; // random bytes
    uint16_t fn_len; // Unicode filename length
    uint8_t blocks; // blocks to encrypt
}
```

```
uint32_t block_size; // block size
uint16_t N_to_steal; // number of bytes to steal
uint32_t N_bytes_mmh; // murmur3 hash of stolen
char RC4_KEY[16]; // RC4_KEY
char stolen_bytes[0]; // stolen bytes
};
```

```
struct FileMetainfo {
    FILETIME Creation; // original CR time
    FILETIME LastAccess; // original LA time
    FILETIME LastWrite; // original LW time
    char orig_fn[0]; // original filename
    uint64_t blocks_mmh[0]; // murmur3 hash of blocks
};
```

The overall structure of an encrypted file was presented in [Figure 1](#), however this can vary depending on the size of encrypted file.

If a single block is encrypted:

```
struct EncryptedFile {
    char rand_bytes[N]; // stolen bytes repl
    char ct[FileSize-N]; // encrypted file data
    FileMetainfo enc_fmi; // encrypted FMI stru
    char enc_fsh[0]; // encrypted FSH stru
    char enc_RSA_X[0]; // encrypted RSA_X_*
};
```

If multiple blocks are encrypted:

```
struct EncryptedFile {
    char rand_bytes[N]; // stolen bytes repl
    char pt_0[K]; // plaintext chunk
    char ct_0[max_block_size]; // ciphertext chunk
    ...
    char pt_y[M]; // plaintext chunk
    char ct_y[max_block_size]; // ciphertext chunk
    FileMetainfo enc_fmi; // encrypted FMI stru
    char enc_fsh[0]; // encrypted FSH stru
    char enc_RSA_X[0]; // encrypted RSA_X_*
};
```

If the file is small:

```
struct EncryptedFile {
    char rand_bytes[N];    // stolen bytes repl
    FileMetaInfo enc_fmi;  // encrypted FMI stru
    char enc_fsh[0];       // encrypted FSH stru
    char enc_RSA_X[0];     // encrypted RSA_X_*
};
```

3. Decryption scheme

Let's discuss the decryption scheme that is used by the Cerber ransomware, after the ransom has been paid. An overview of the decryption scheme is shown in [Figure 2](#).

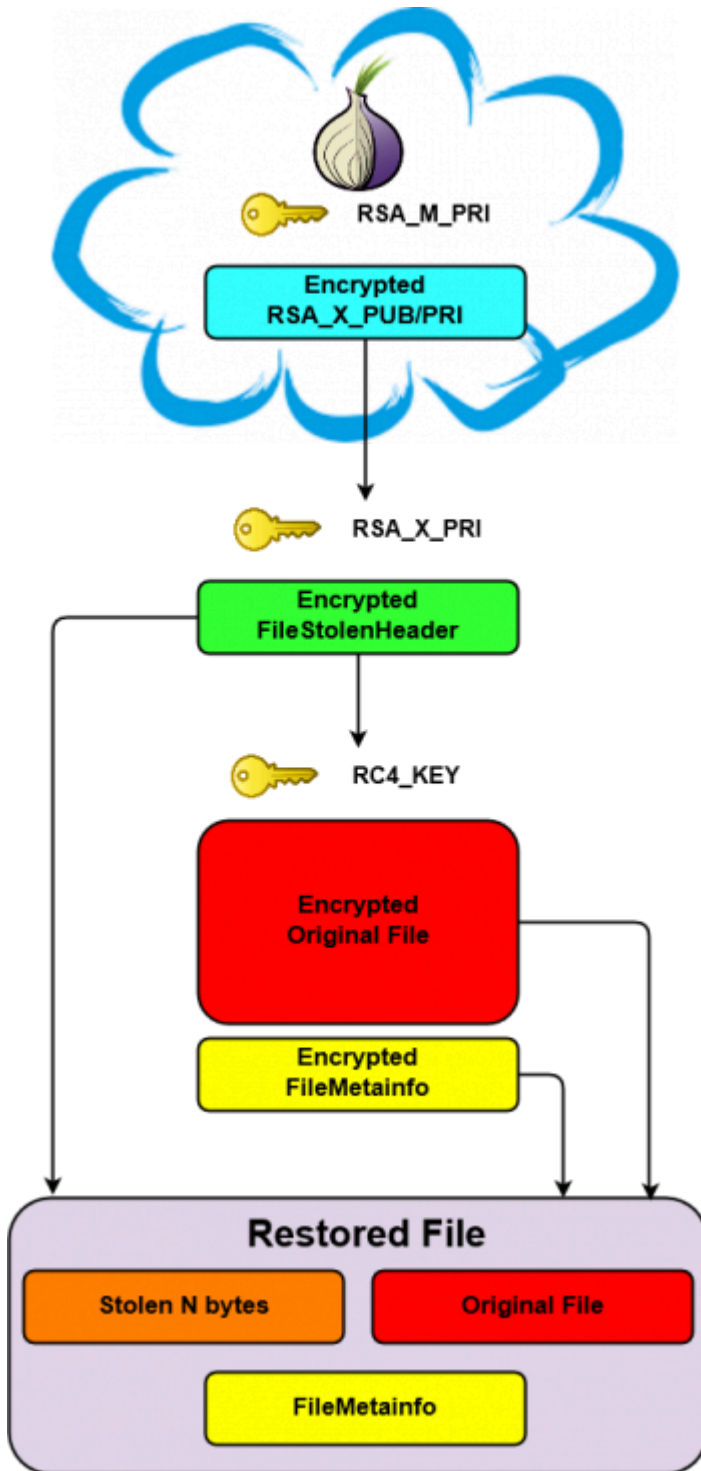

Figure 2: Decryption scheme.

The following steps are performed by the decryptor in order to restore encrypted files:

1. Extract encrypted blob of RSA_X_PUB/PRI (hereafter ENC_RSA_X_BLOB) from the end of the encrypted file and send it to the server.
2. Decrypt RSA_X_PRI on the server by using RSA_M_PRI and send it to the client. RSA_M_PRI is the master private key and is known only to the attacker.
3. Use the obtained RSA_X_PRI to decrypt the FileStolenHeader structure, thus restoring RC4_KEY and the stolen bytes.
4. Decrypt encrypted blocks by using RC4_KEY.

5. Restore original file content by combining stolen header with the decrypted blocks.
6. Decrypt FileMetainfo structure using RC4_KEY and restore file meta information.

As we can see, the decryption routine is not complicated. The only blind spot is the RSA_M_PRI key. Factorization of a 2048-bit number is a nice challenge [6], but is definitely not what we want to deal with, because cracking such a long key is not feasible in a reasonable amount of time.

Let's take a look at how the decryptor communicates with the server in order to obtain RSA_X_PRI, which is critical for the decryption process. The decryptor encodes ENC_RSA_X_BLOB using a base64 algorithm (hereafter PRIVATE_KEY). The ID of the infected machine is calculated as an MD5 of the previously encoded block (hereafter SIGN) (see Figure 3).

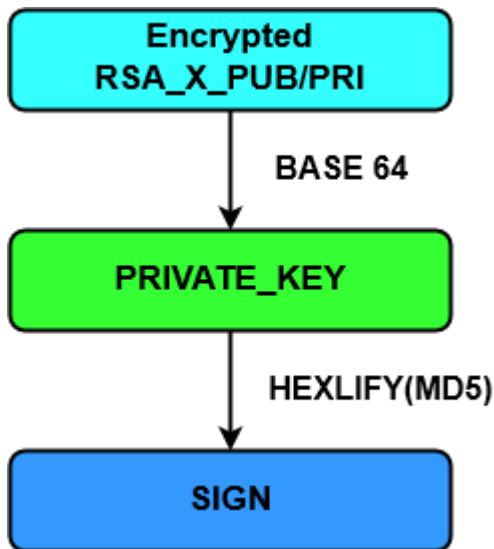

Figure 3: Signature generation.

The first message contains only the machine ID, which is sent using the following format:

```
"sign=%s" % SIGN
```

The response from the server contains a CAPTCHA image, which must be solved to continue decryption. We assume that this is done to protect the decryption server from the DDoS.

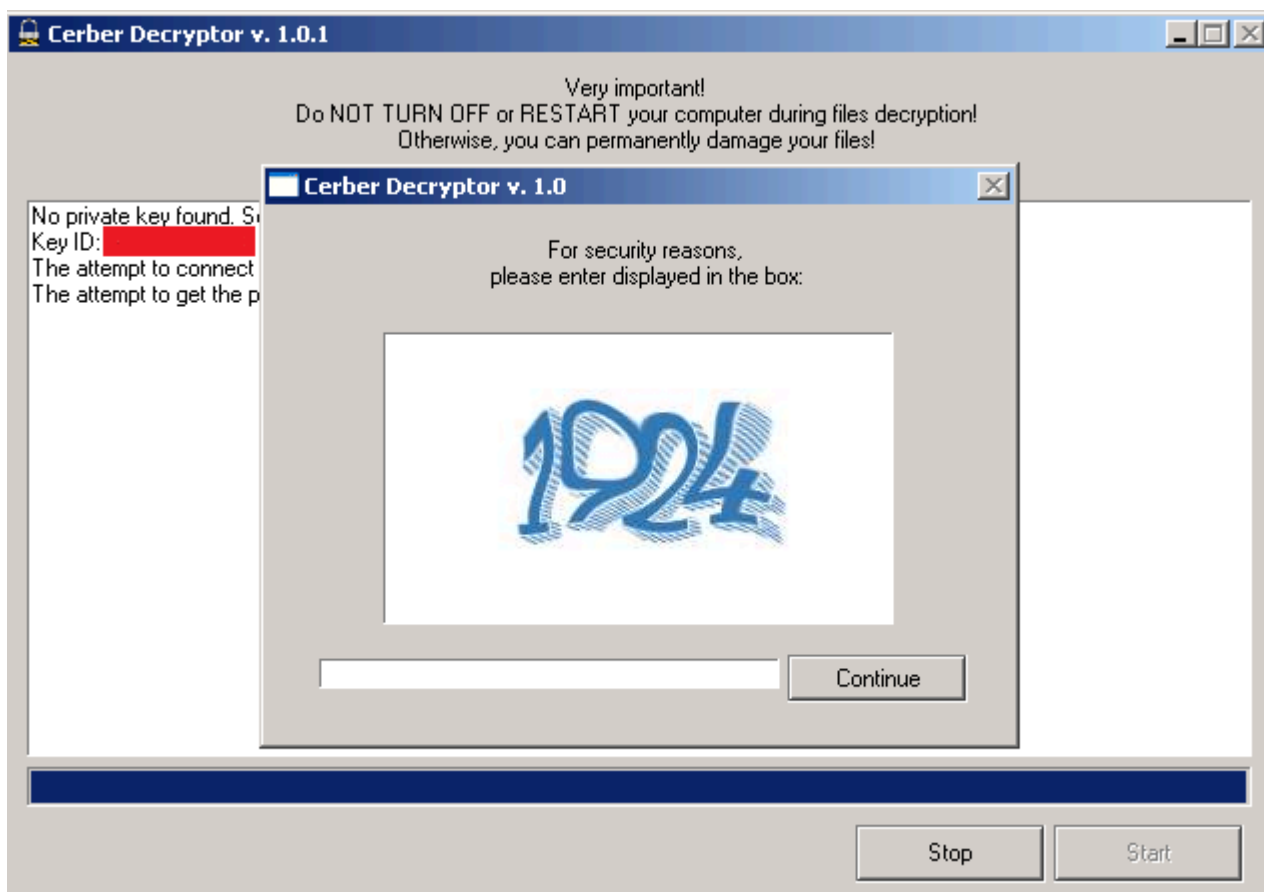

Figure 4: CAPTCHA.

The CAPTCHA solution, together with PRIVATE_KEY and SIGN, are sent to the server using the following format:

```
"captcha=%d&sign=%s&private_key=%s" % (CAPTCHA, SIGN, PRIVATE_KEY)
```

If the CAPTCHA has successfully been solved and the specified machine ID has made the ransom payment, the server decrypts RSA_X_PRI and sends it back to the client. Then the decryptor starts the file restore process.

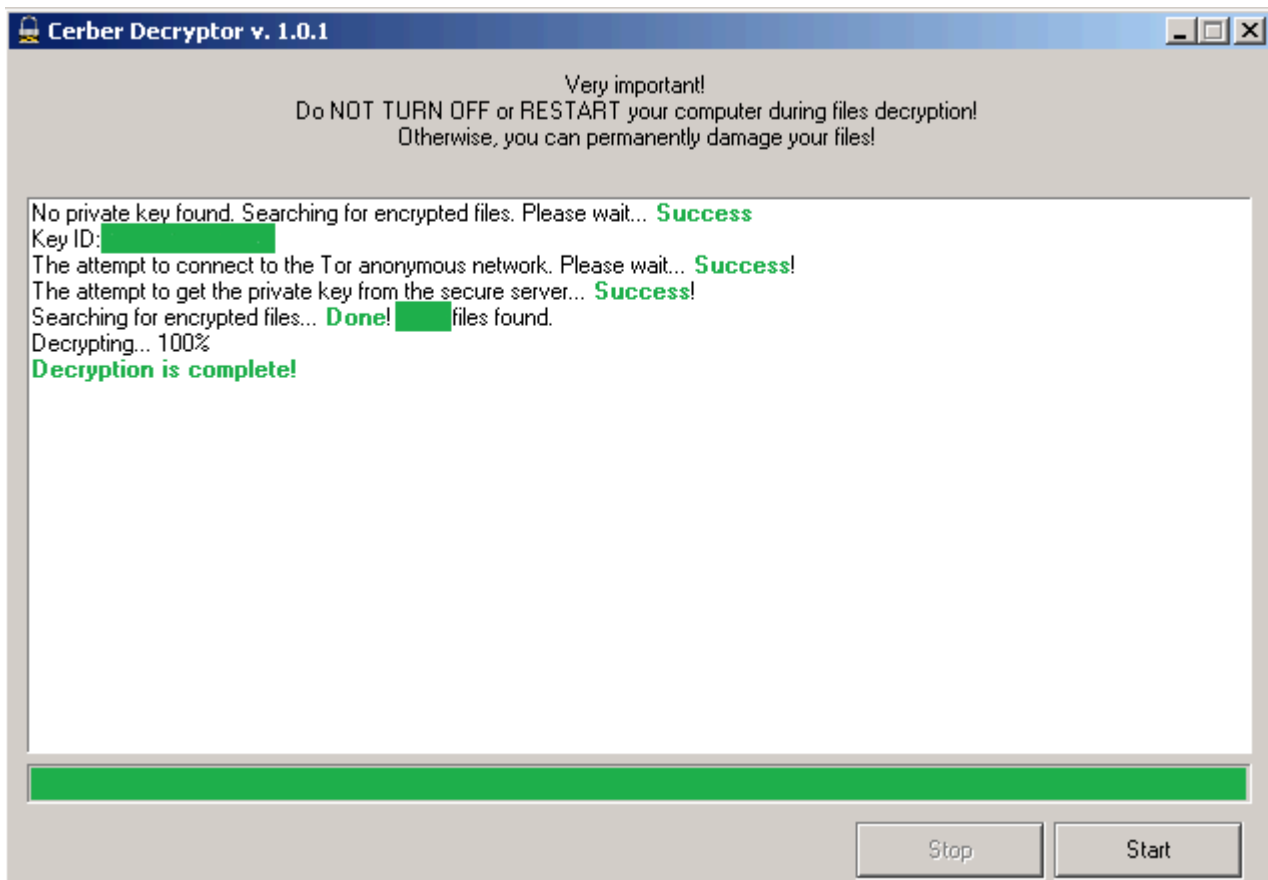

Figure 5: Successful decryption.

If the ransom for the specified machine ID is not paid, the user receives the message shown in Figure 6 during communication with decryption server.

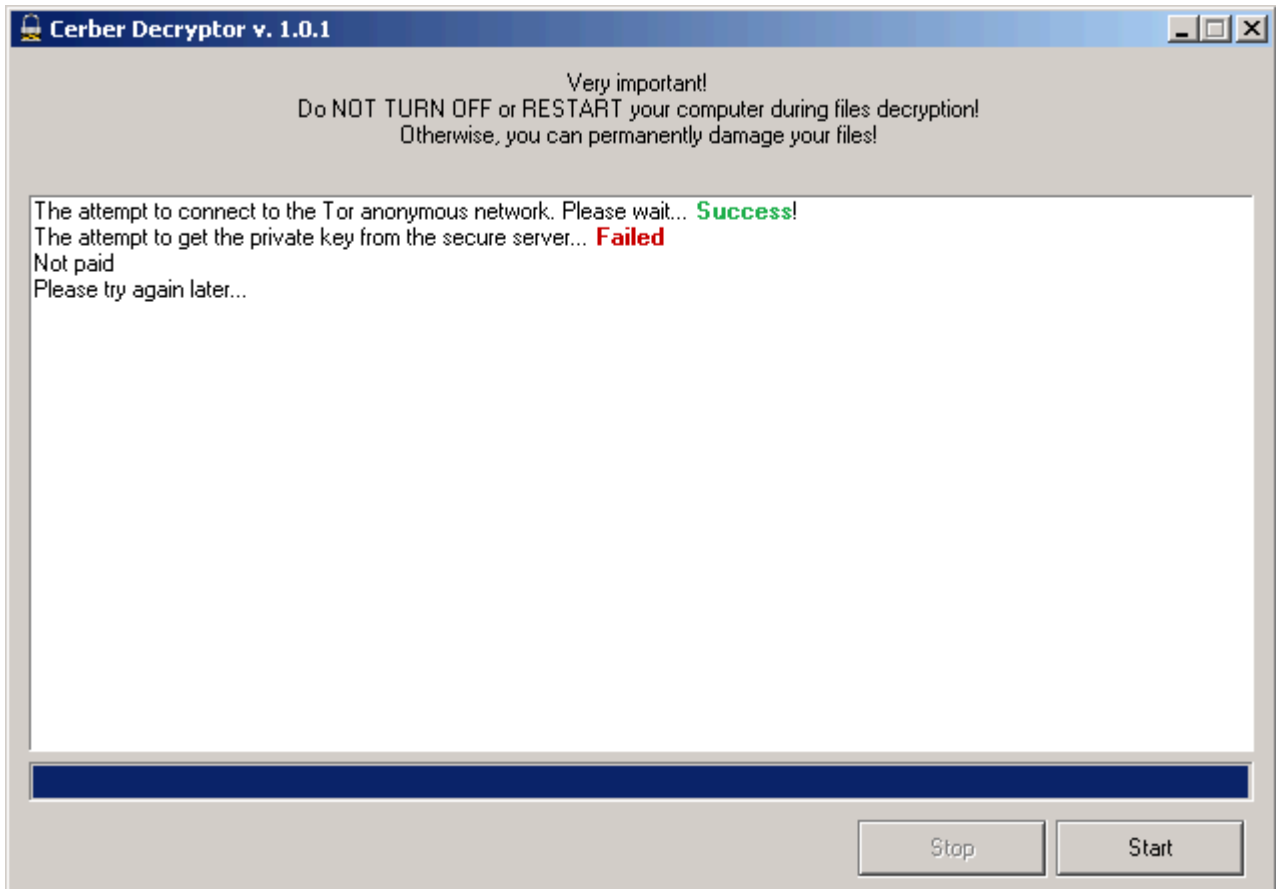

Figure 6: Ransom not paid.

Now we have familiarized ourselves with the decryption scheme and communication method, let's consider what can go wrong in the existent solution.

4. Fatal flaw

This section describes the approaches that were used to find a flaw in the decryptor. First, we should understand how exactly the server validates that the ransom has been paid for a specific machine. The most obvious answer is the use of the SIGN field. If the ransom is paid for SIGN, the server decrypts PRIVATE_KEY and sends RSA_X_PRI to the user. Let's try to rewrite the server code that is responsible for handling decryption requests from users based on received responses:

```
def handle_request_decrypt_private_key(packet):
    if not captcha_correct(packet['captcha']):
        send({'error': "Captcha expired or invalid"})
        return
    if not paid(packet['sign']):
        send({'error': "Not paid"})
        return
    pk = urls_to_b64(packet['private_key'])
    #*****
    # DOES SERVER SIDE HAVE SUCH INTEGRITY CHECK ??
    if md5(pk).hexdigest() != packet['sign']
```

```

send('{???}')
return
#*****
RSA_X_PRI = decrypt(b64decode(pk))
send('{"error": "null", "private_key": "%s"}' %\
    encode(RSA_X_PRI))

```

Now let's try to recreate the server's exact behaviour based on the received responses and common sense:

1. Check if CAPTCHA is correct.
2. Check if SIGN is paid. Server treats SIGN as a unique machine ID.
3. Perform integrity check on delivered PRIVATE_KEY using SIGN, because SIGN is the hexlified MD5 of PRIVATE_KEY.
4. Decrypt PRIVATE_KEY and extract RSA_X_PRI.

The first two steps can easily be checked by sending an incorrect CAPTCHA solution and SIGN that is unpaid. The third step is what we are really interested in.

Let's imagine that SIGN_A signature is paid and we have a possibility to restore RSA_X_PRI_A. RSA_X_PRI_A is restored from the PRIVATE_KEY data that is under the sender's control. So what happens if the user spoofs that data?

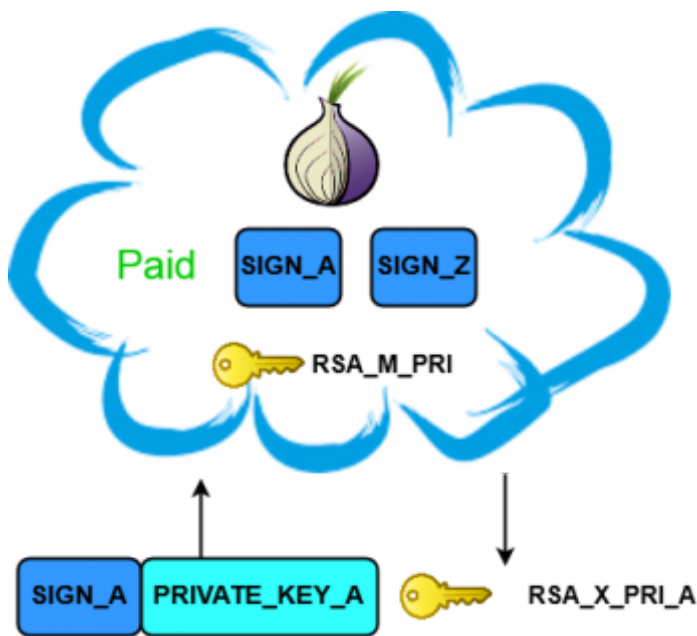

Figure 7: Original PRIVATE_KEY for the paid

SIGN.

Let's think what exactly we can achieve by setting PRIVATE_KEY to prepared data assuming SIGN_A is paid. What will happen if we can calculate PRIVATE_KEY_V for another infection? Assuming that a data integrity check is absent, then the server will simply decrypt PRIVATE_KEY_V and extract RSA_X_PRI_V, thus giving the possibility to restore infected files for the user who hasn't paid! By applying the same tactics to all infected machines, we can restore them by using only one valid SIGN.

If the server does not perform an integrity check of the PRIVATE_KEY data, then it is decrypted and the RSA_X_PRI_V key is sent to the user. The user then adopts that key to restore encrypted files.

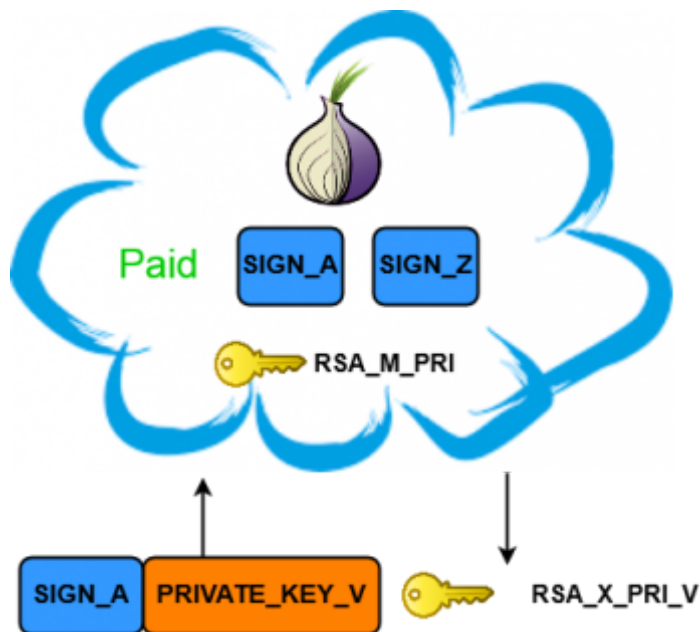

Figure 8: Spoofed PRIVATE_KEY for the paid

SIGN.

To showcase this theory we paid the ransom for one infection that was performed on a specially prepared machine. All the checks on the server side passed and the decryption process succeeded (Figure 9).

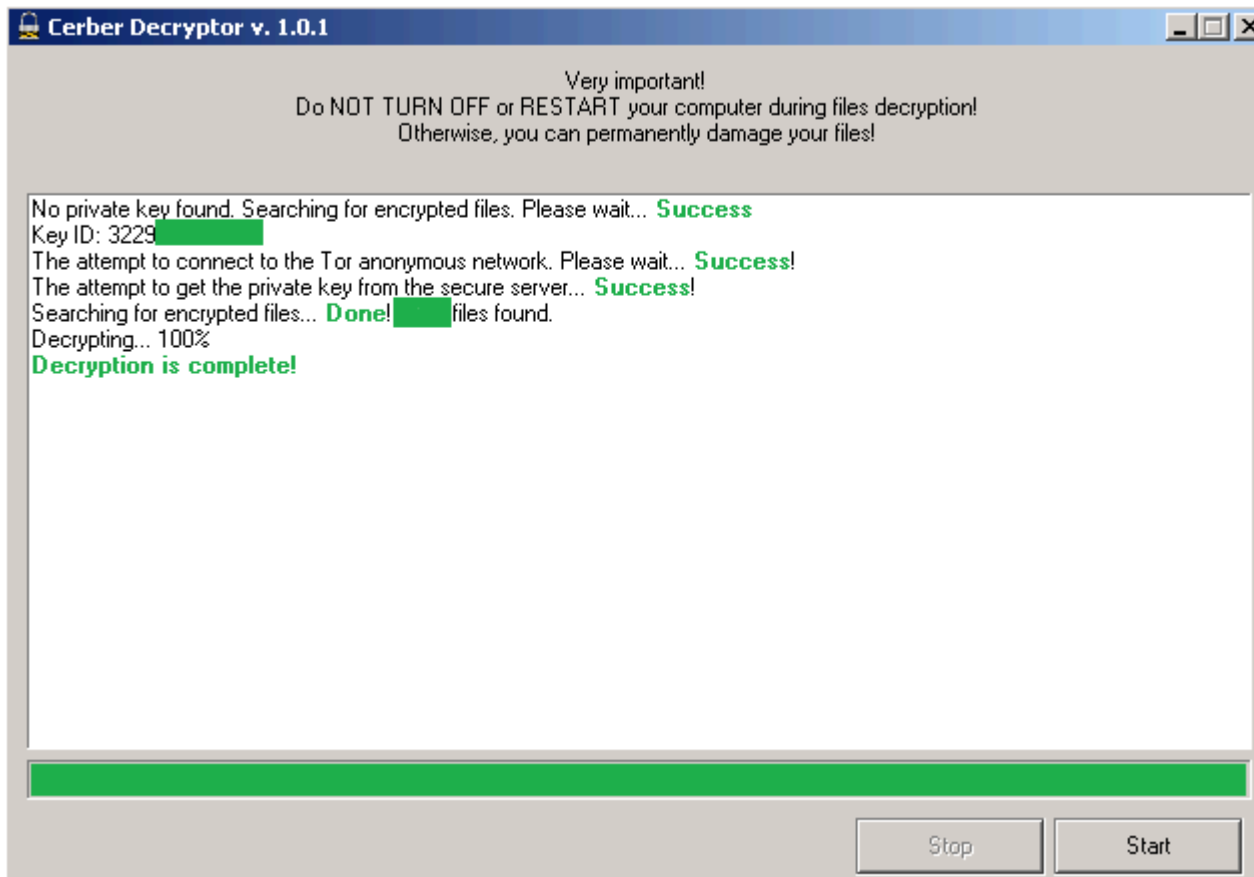

Figure 9: Successful decryption for original PRIVATE_KEY.

Next, a second machine was infected and encrypted with the Cerber ransomware. It obviously had a different PRIVATE_KEY. The original decryptor was dirty patched to use the same SIGN as was previously paid. We started the decryptor on the second infected machine, and all the data on the infected machine was decrypted! (Figure 10).

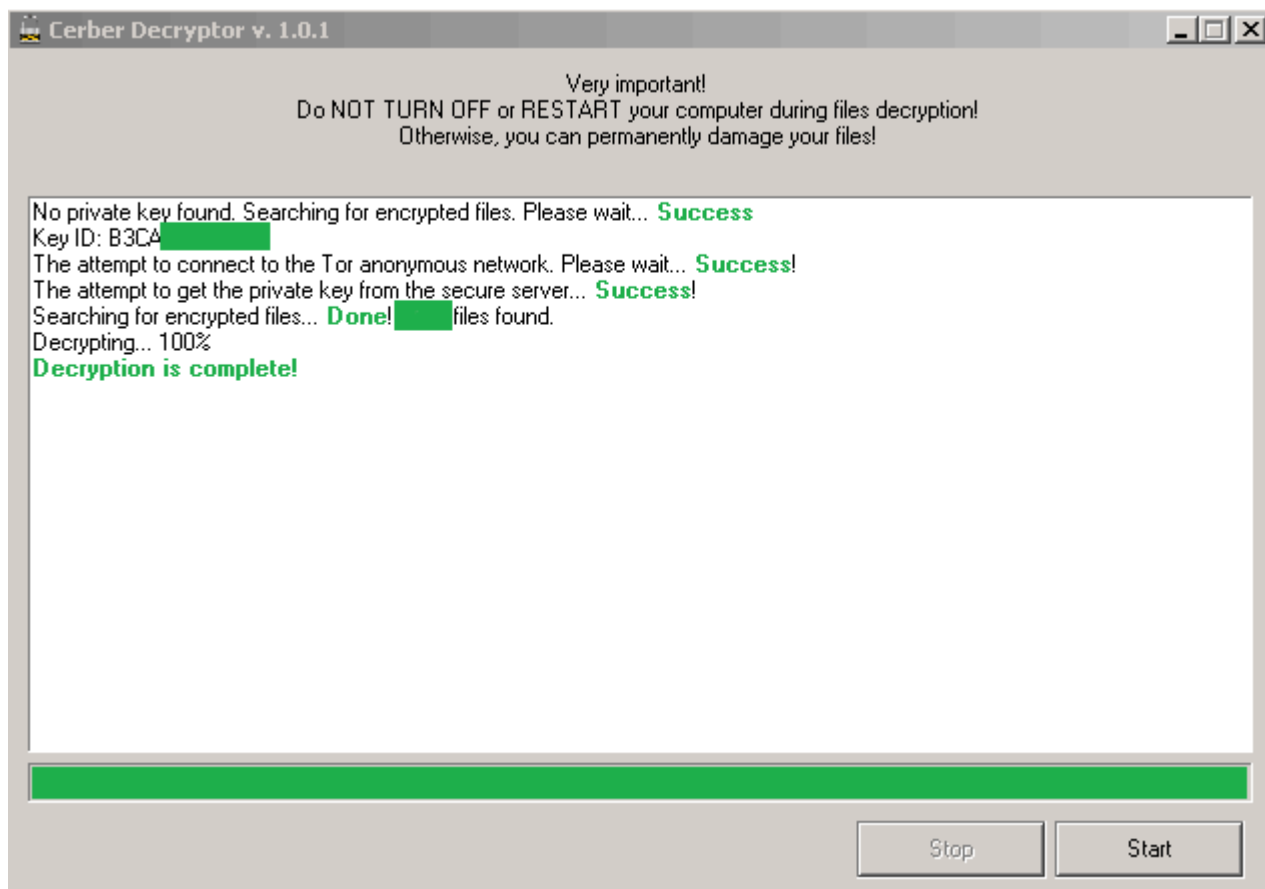

Figure 10: Successful decryption for spoofed PRIVATE_KEY.

The Cerber authors simply did not perform a data integrity check, thus giving us the possibility to exploit this bug and decrypt machines with only one paid signature.



Figure 11: Data integrity

check that authors have skipped.

5. Decryption service installation

This section provides a general description of what actions were performed in order to establish a decryption service as soon as possible after the vulnerability was discovered. Our two main goals were to hide the flaw from the attackers for as long as possible and to make the bandwidth for decryption as wide as possible.

In order to fulfil both requirements we decided to set up a server that would be responsible for fetching the keys. After being fetched, the obtained key would be sent to the infected user. This key would then be used by the

client-side decryptor to restore the files. Figure 12 provides an overview of the process.

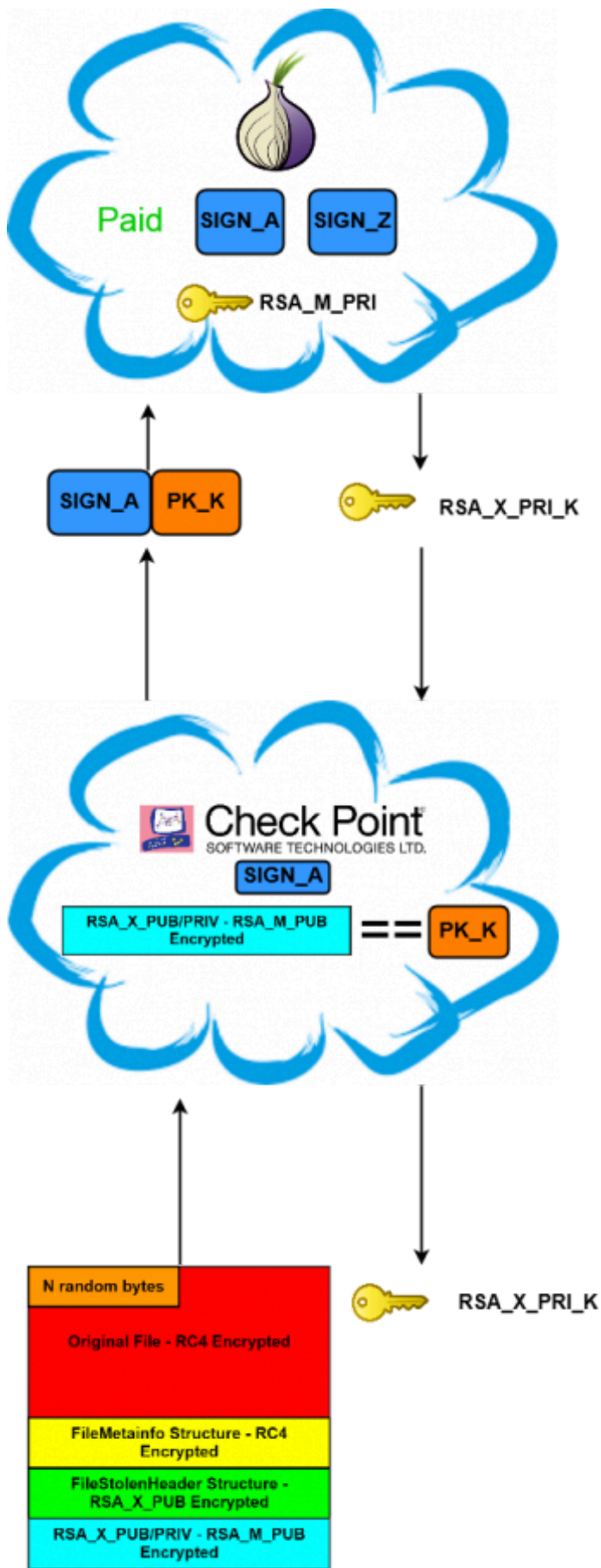

infection.

Figure 12: Fetching decryption key for specific

The following steps are taken in order to retrieve the decryption key for a specific infection:

1. User uploads encrypted file from the infected machine to the *Check Point Decryption Service (CPDS)*.
2. *CPDS* extracts *ENC_RSA_X_BLOB* from the received file, which is aliased with *PRIVATE_KEY_K*.
3. *PRIVATE_KEY_K* is sent to the Cerber Decryption Server (*CDS*) together with the paid *SIGN_A*.
4. *CDS* checks if *SIGN_A* is paid and decrypts the *RSA_X_PRI* client private key by using *RSA_M_PRI*.
5. *CDS* sends *RSA_X_PRI_K* in a specific format to the *CPDS*.
6. *CPDS* extracts *RSA_X_PRI_K* and sends the file with its content to the user.
7. User uses the obtained file together with the *RSA_X_PRI_K* in order to restore encrypted files by the running prepared application.

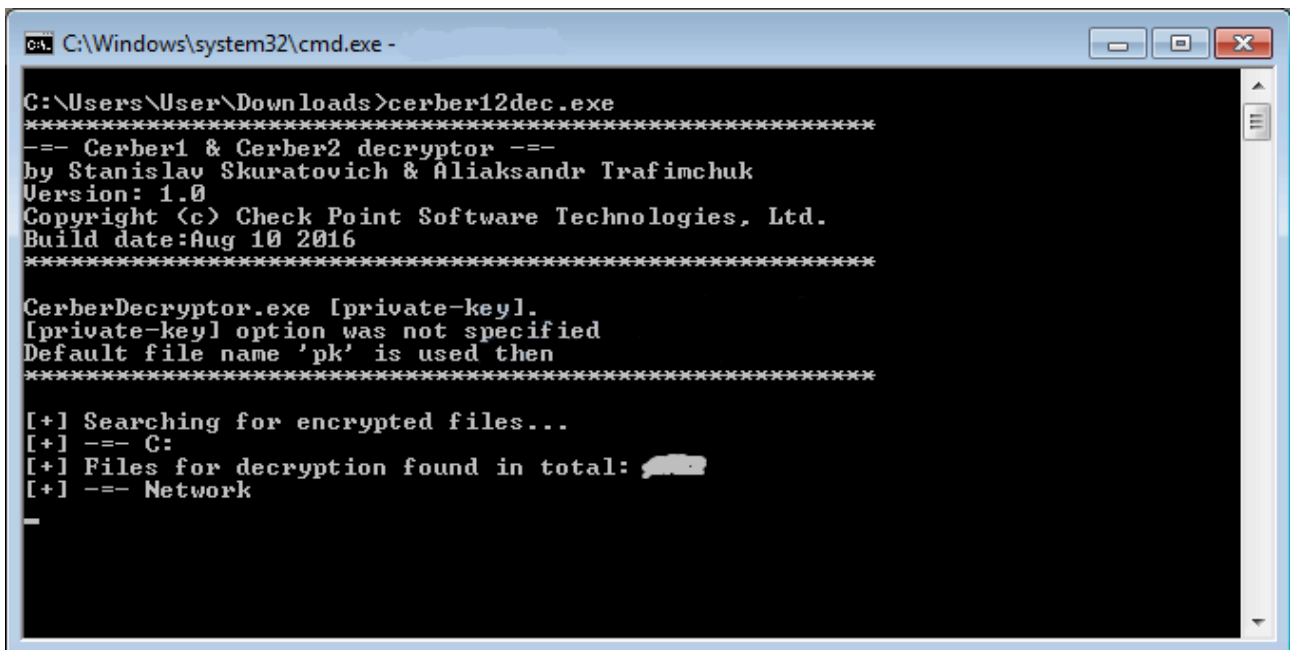

Figure 13: Infected machine decryption process.

In order to parallelize victims' requests and reduce both the waiting time and server bug fixing, four decryption signatures were purchased. With that number of keys we were able to handle up to 20,000 decryption requests per day.

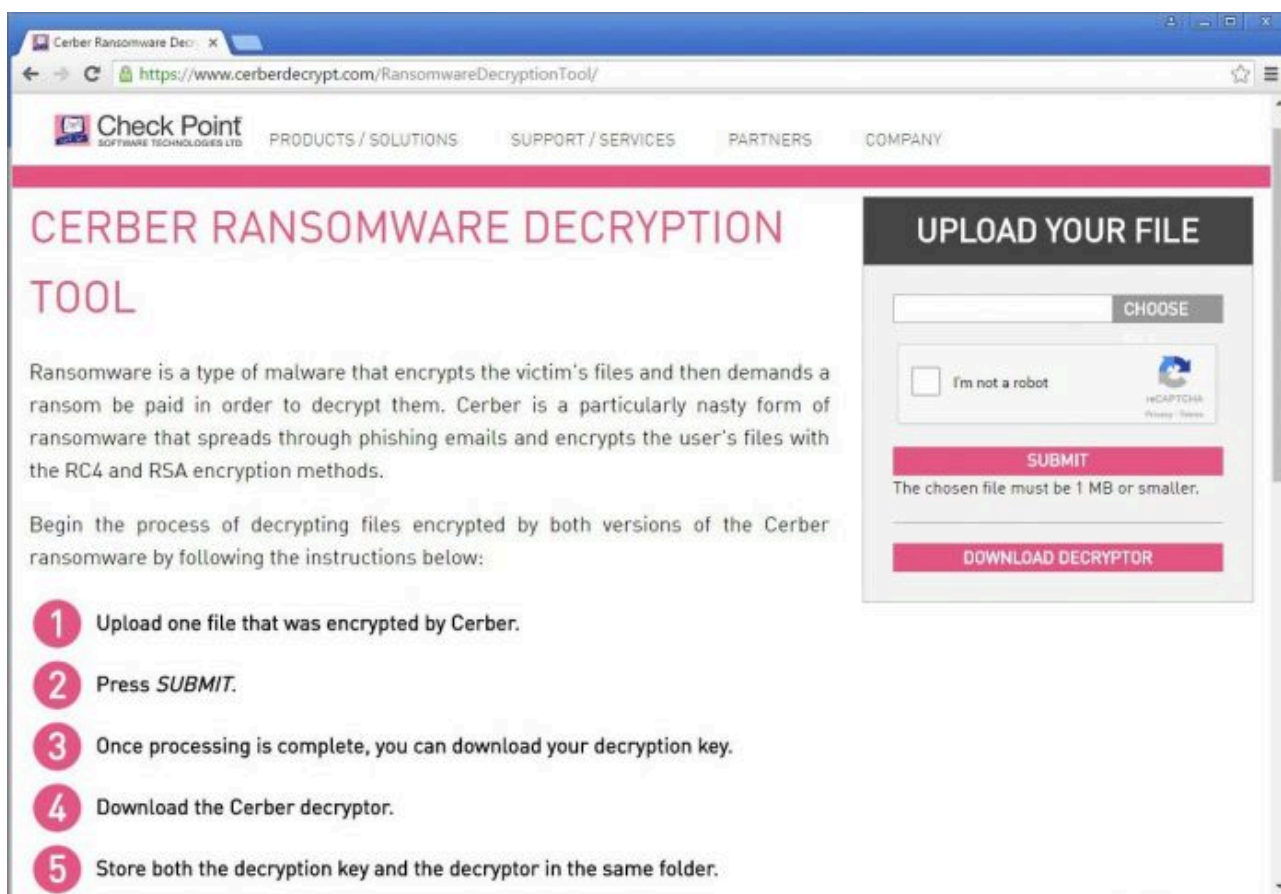

Figure 14: Check Point Cerber Ransomware Decryption Tool.

Now that we have examined the server-side flaw that gave us the chance to decrypt infected computers, let's take a look at the Cerber ecosystem and associated money laundering.

6. A ransomware-as-a-service ecosystem

Cerber ransomware-as-a-service illustrates every aspect of an effective business franchise. The actor behind the operation, dubbed 'crbr', offers the ransomware for sale through a private, carefully managed affiliate program – actors who are willing to distribute the ransomware are granted a comprehensive use panel through which they can monitor the rate of the infections, encryption process and ransom payments. In return, 40% of the profits are transferred to 'crbr' as a fee. Based on data collected by our sensors, during July 2016 Cerber affiliates ran over 150 active campaigns, infecting nearly 150,000 victims, with a total estimated profit of US\$195,000 per month, which adds up to US\$2.3 million per year (the numbers are based on a Bitcoin conversion rate of US\$590). In fact, the Cerber ransomware demonstrates a growth rate higher than that of major global fast food chains.

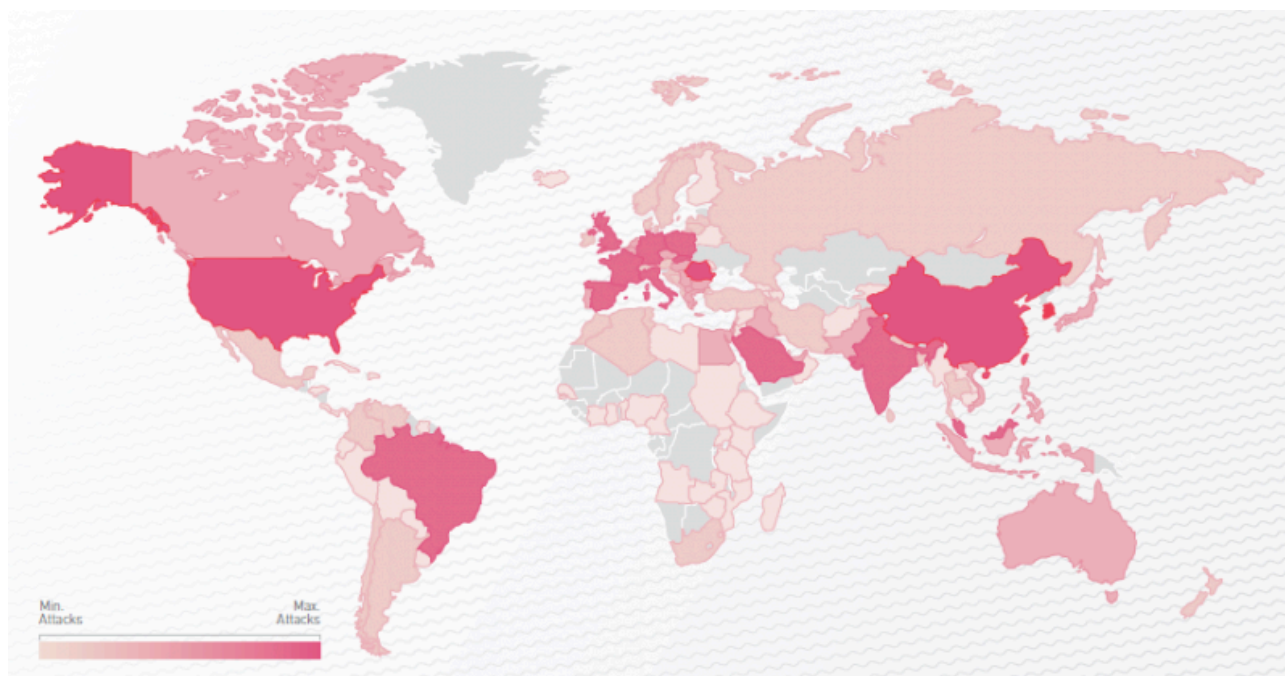

Figure 15: Cerber global distribution map.

7. Following the money trail

Cerber generates a unique Bitcoin wallet to receive funds from each victim. The generated wallet appears in the landing page shown to the victim, represented by an encoded string in the URL. *Check Point* researchers examined tens of thousands of victim Bitcoin wallets, and found that only 0.3% of the victims chose to pay the ransom. But the bigger question is: once a Bitcoin transaction occurs, what happens to the money? Based on our analysis, it seems that Cerber uses a Bitcoin mixing service as part of its money flow in order to remain untraceable. A mixing service allows the ransomware author to transfer Bitcoins and receive the same amount back to a wallet that cannot be associated with the original owner. This is achieved by mixing multiple users' funds together, using tens of thousands of Bitcoin wallets, making it almost impossible to track them individually (see [Figure 16](#)). Based on our research, automated tools distribute the affiliate shares only after the money has been swapped by the mixing service and the malware author's share has been collected.

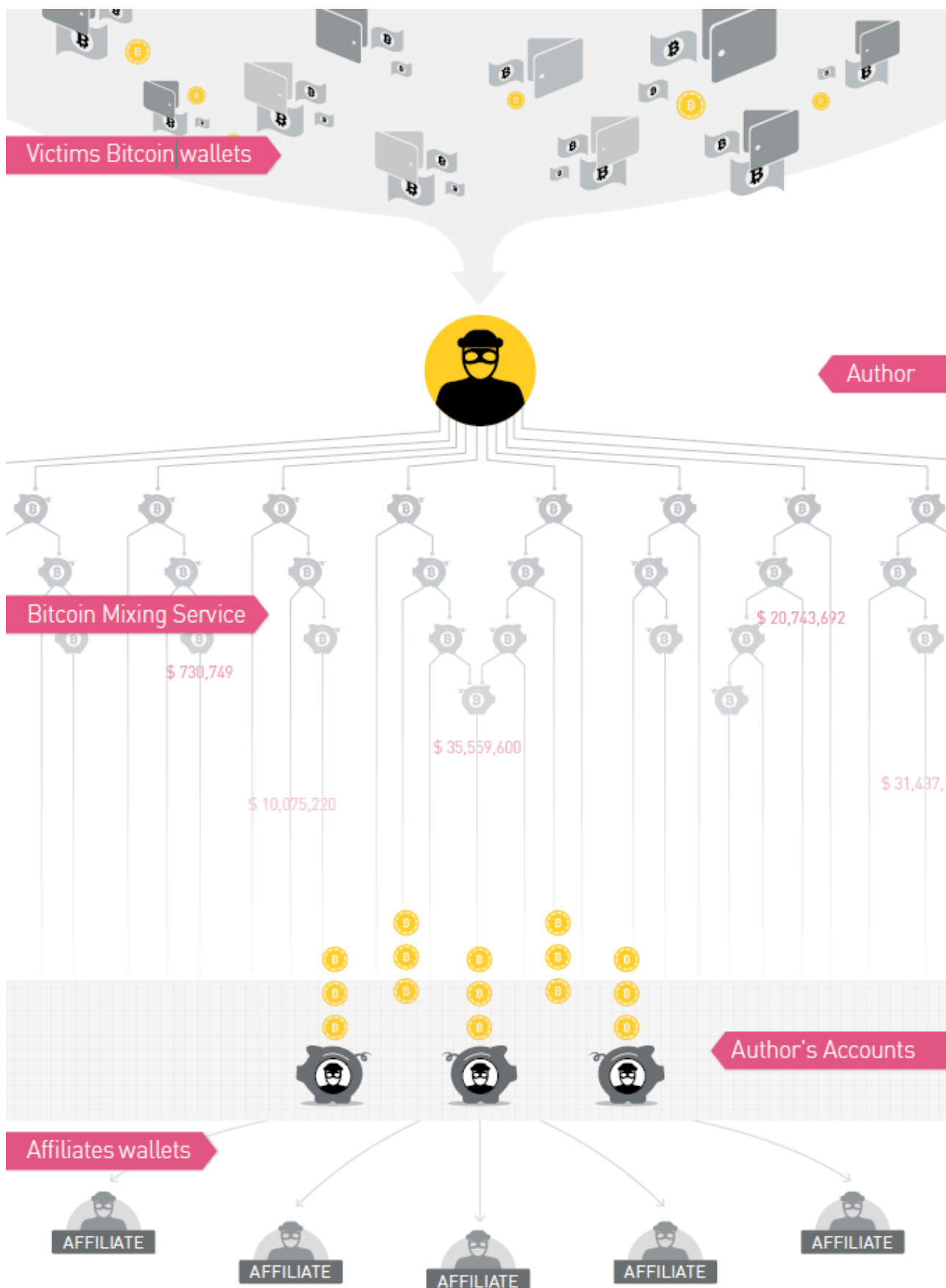

Figure 16: Cerber Bitcoin flow.

Summary

Thousands of users restored their files while the *Check Point Cerber Decryption Service* was active. Unfortunately, the attackers were quite responsive and fixed the vulnerability within 24 hours.

Cerber ransomware-as-a-service uses a business model that has been proven to be effective by some of the biggest franchise businesses worldwide. Furthermore, the malware author uses a sophisticated money flow to ensure that the profits remain sealed and that its Bitcoin wallets cannot be associated with the attack operation. It is therefore little wonder that Cerber ransomware is one of the most widespread pieces of ransomware of our time.

Acknowledgements

We would like to thank the *Check Point* Malware Research and Threat Intelligence teams and in particular Aliaksandr Trafimchuk for his devoted help throughout the research.

References

- [1] Cerber Decryptor. <http://blog.trendmicro.com/trend-micro-ransomware-file-decryptor-updated/>.
- [2] Check Point Releases Working Decryptor for the Cerber Ransomware. <https://www.bleepingcomputer.com/news/security/check-point-releases-working-decryptor-for-the-cerber-ransomware/>.
- [3] Cerber 2 Ransomware: Free Decryption Tool Released. <http://www.bankinfosecurity.com/cerber-2-ransomware-free-decryption-tool-released-a-9341>.
- [4] Cerber. <http://blog.checkpoint.com/2016/08/16/cerberring/>.
- [5] Source code. <https://github.com/CheckPointSW/CerberDecryptionService>.
- [6] RSA Factoring Challenge. https://en.wikipedia.org/wiki/RSA_Factoring_Challenge.

Source: <https://www.virusbulletin.com/virusbulletin/2017/12/vb2017-paper-nine-circles-cerber/>